

MICRO-Z

SET-UP INSTRUCTIONS

**VERY IMPORTANT!
READ INSTRUCTIONS
CAREFULLY AND
FOLLOW STEP BY STEP
SET-UP PROCEDURE**

Recommended tools and accessories.

- 1 - Variable speed, reversible drill with #3 Phillips screwdriver tip.
- 2 - 3/4" Flat wrenches.
- 2 - 9/16" Combination wrenches.
- 1 - Utility knife.
- 1 - 2' Level.

Step1: Removal of Micro-Z from pallet.

- (A) Use a fork lift to unload the unit from the truck. See fig. 1
- (B) Remove the wrapping materials.
- (C) Remove rim, bottom pad and backboard.
- (D) Remove two lag screws which hold the base to the pallet.
- (E) Carefully rotate the Micro-Z down to the floor as shown in fig. 2

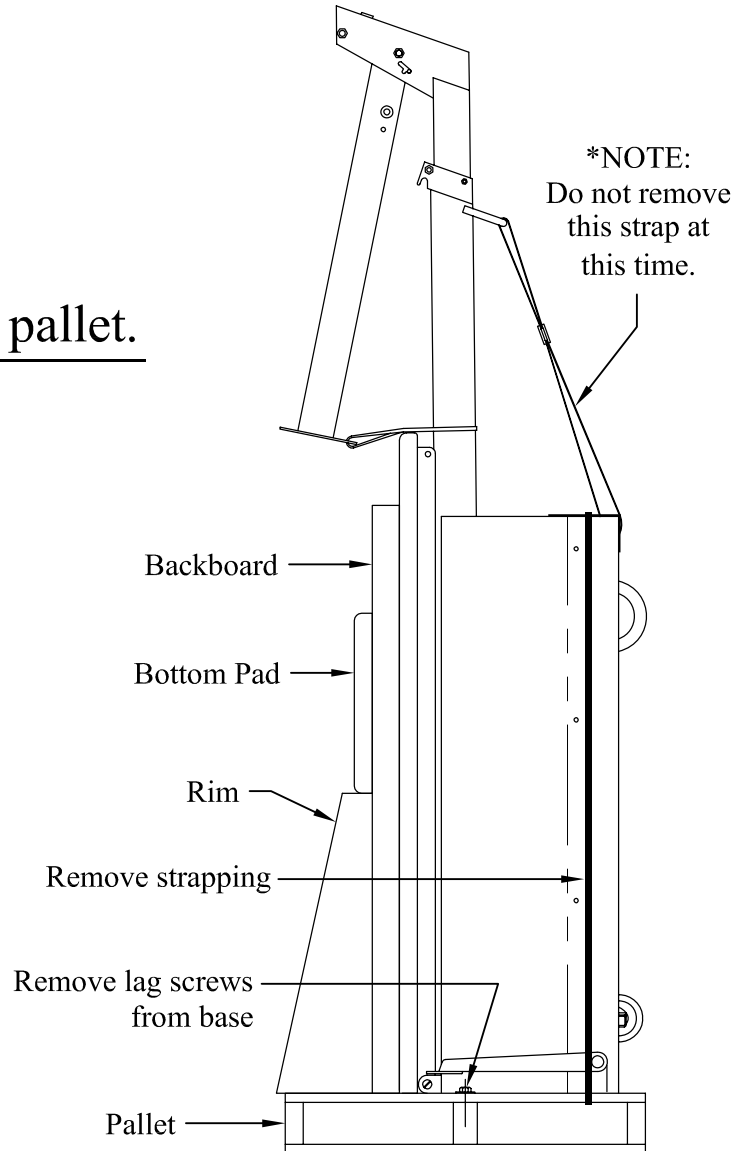

Figure 1.

Carefully rotate unit off of pallet and onto floor. Suggest using at least two persons for this task.

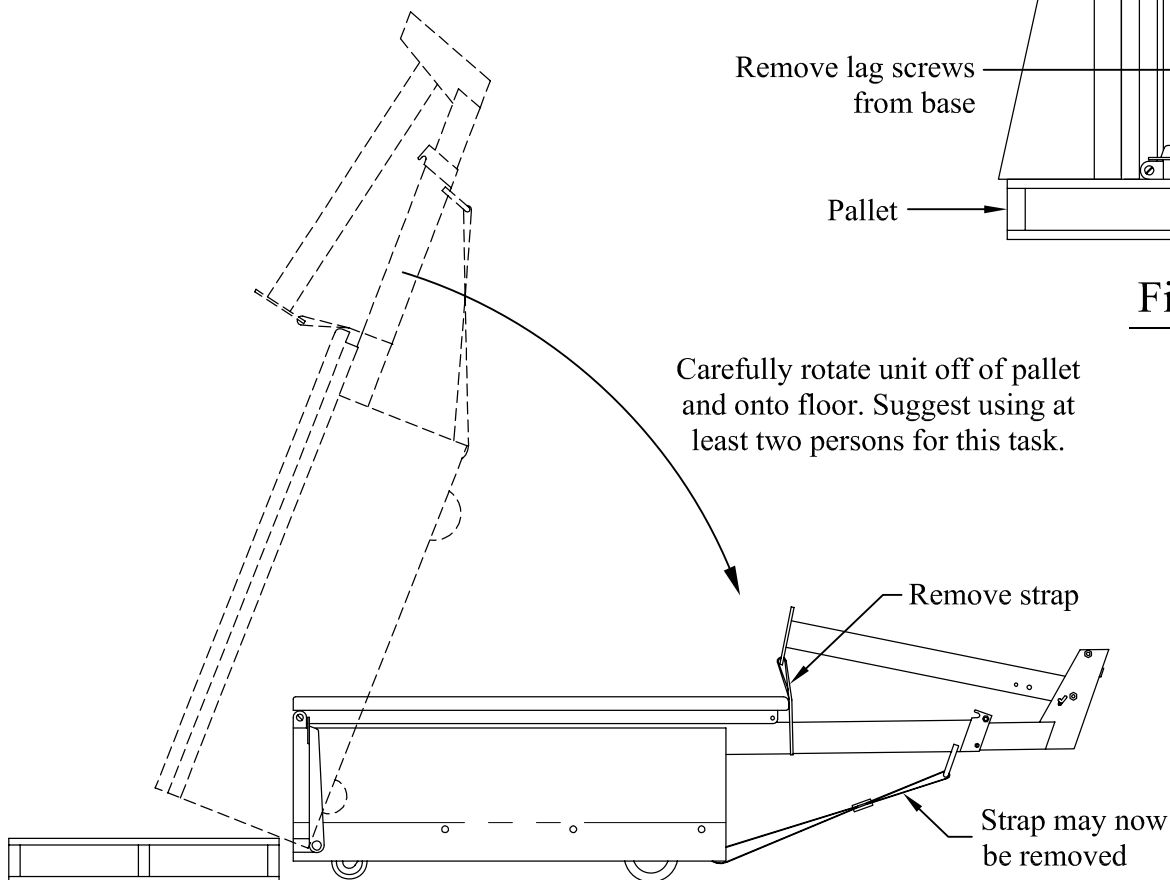

Figure 2.

Step 2: Raise and secure main post.

- (A) Unscrew 1/2" bolt and remove extension boom till later step. See fig. 3
- (B) Set foot brake. See fig. 4
- (C) Carefully raise main post to full vertical position as illustrated in fig. 4
- (D) See Detail View for final step in securing post.

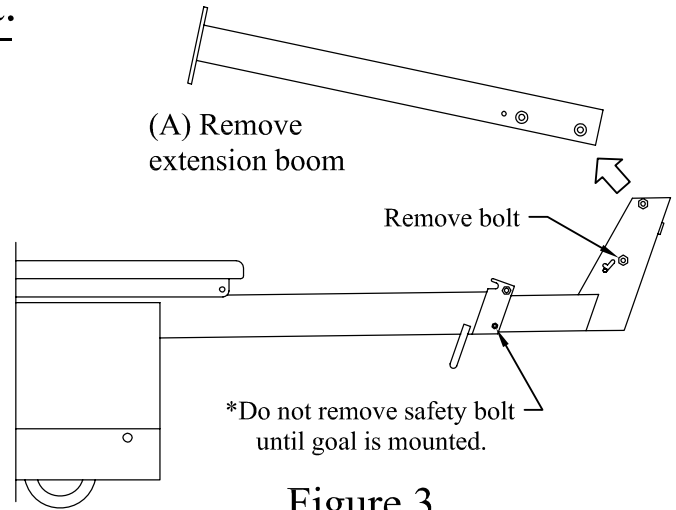

Figure 3.

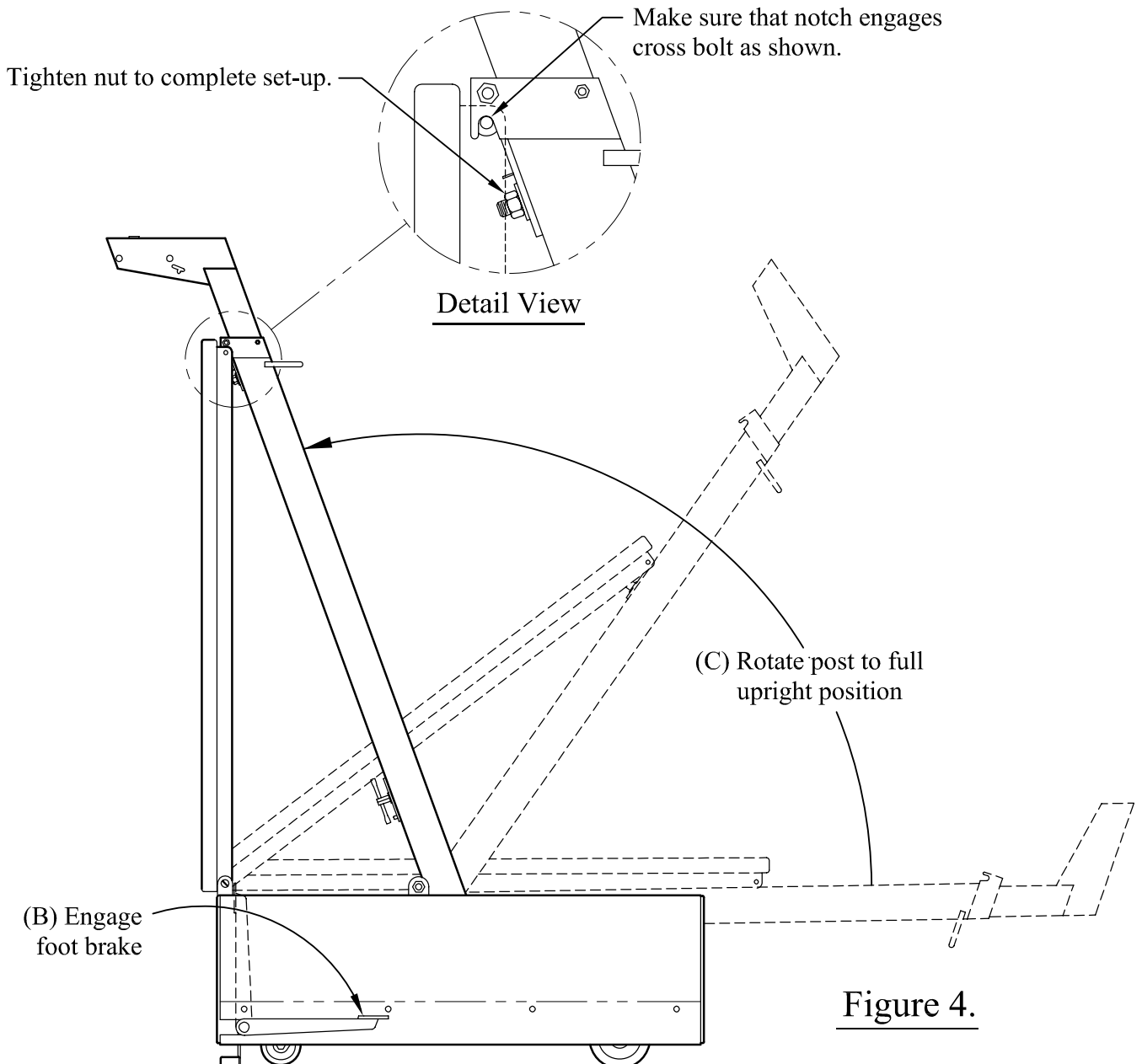

Figure 4.

Step3: Installing ballast.

- (A) Use appropriate screwdriver or powered driver to remove side covers from base.
- (B) Attach bottom front pad.
- (C) Add weights to rear of base. Total weight should be 260 to 320 lbs. Patio blocks shown. Sand bags or other weights may also be used.
- (D) Replace the side covers.

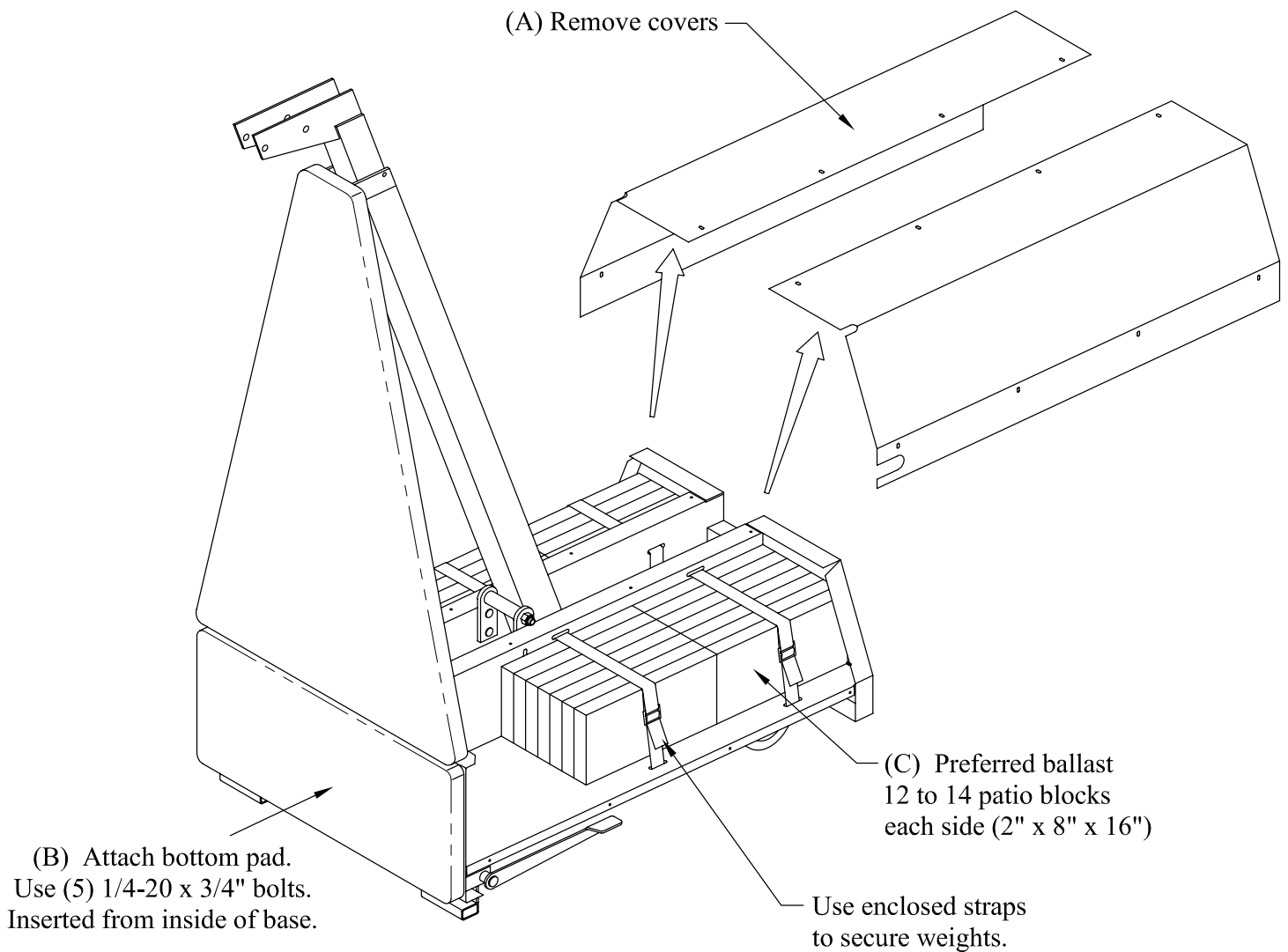
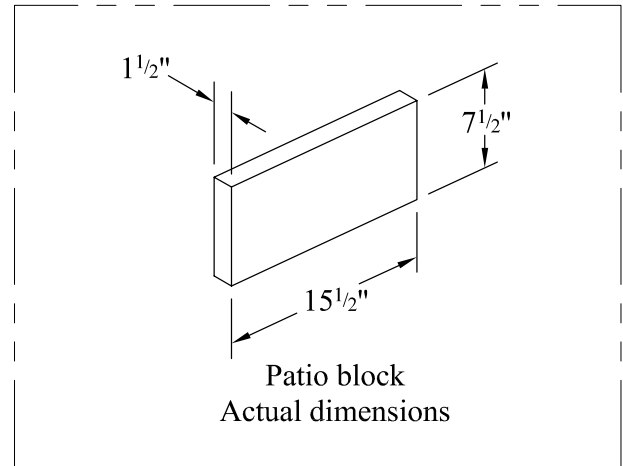

Figure 5.

Step 4: Assemble backboard and extension boom.

*NOTE: Since goal, backboard and boom are connected with the same four bolts, it is suggested to pre-assemble all items on the floor as shown. Follow all notes in fig. 6 Leave bolts snug till step 5.

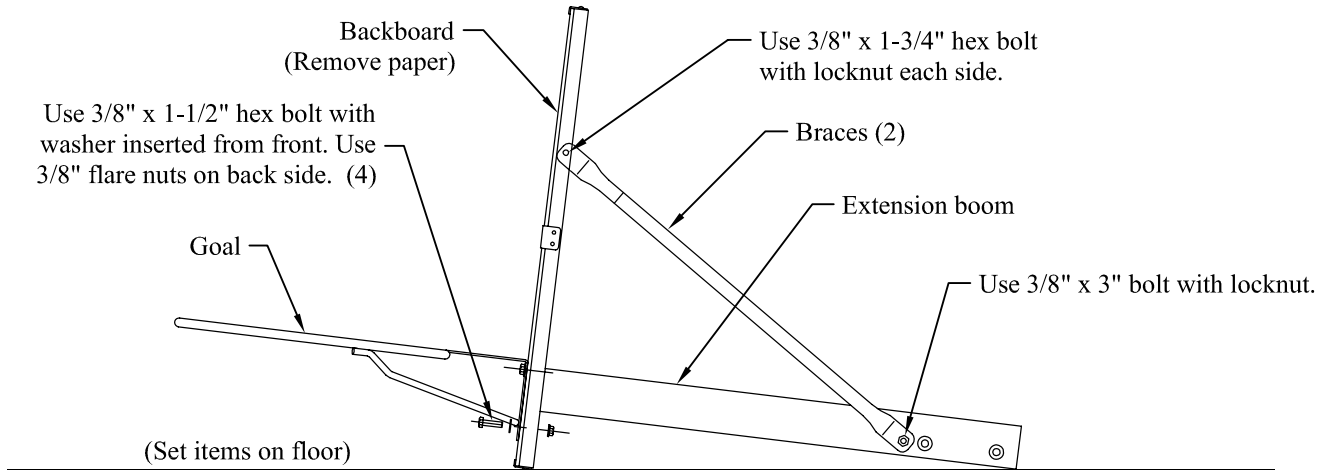

Figure 6.

Step 5: Attach backboard to support post.

(A) Hoist backboard assembly up to support bracket and insert 1st bolt. It is helpful to have two persons for this procedure.

(B) Swing the backboard unit up to a horizontal position. Insert 2nd bolt.

(C) Level extension boom and tighten 1/2" bolts at the support bracket. (Make sure foot brake is set)

(D) Use level to align backboard and goal vertically and horizontally.

(E) Tighten all bolts.

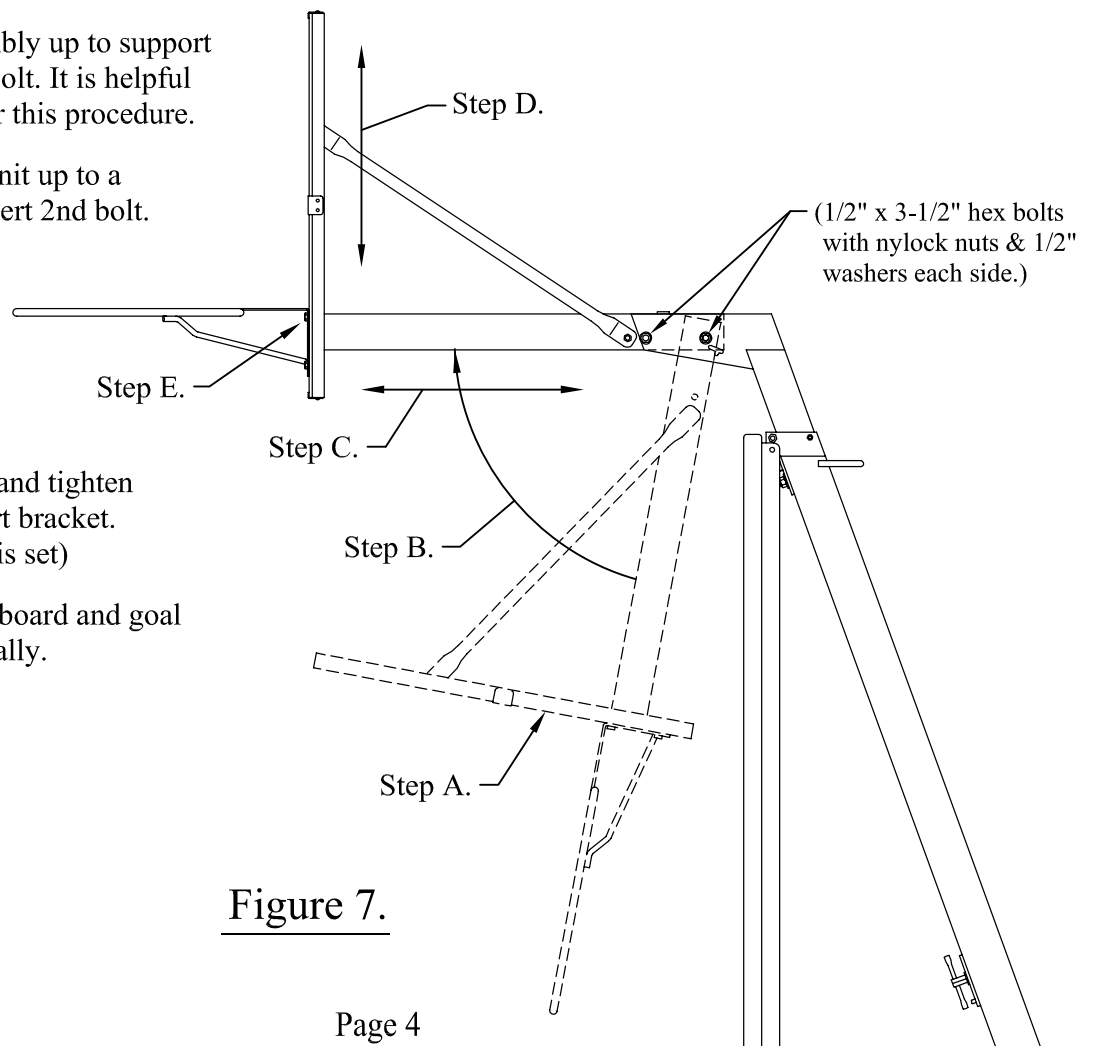

Figure 7.

Step 6. Goal height adjustment.

Make sure locking lever is tight before starting Step 6.

- (A) Remove Safety bolt.
- (B) Unscrew locking lever.
- (C) Use lift handle to raise and lower backboard.
- (D) Use side scale to set height.
Goal adjustable from 7-10 feet.
- (E) Re-tighten locking lever.
Tighten lever until the lift handle plate is firmly against the mast post.
Tighten an additional 1/4 turn.

CAUTION
Do not overtighten locking lever.
Damage to threads may occur
when lever is overtightened.

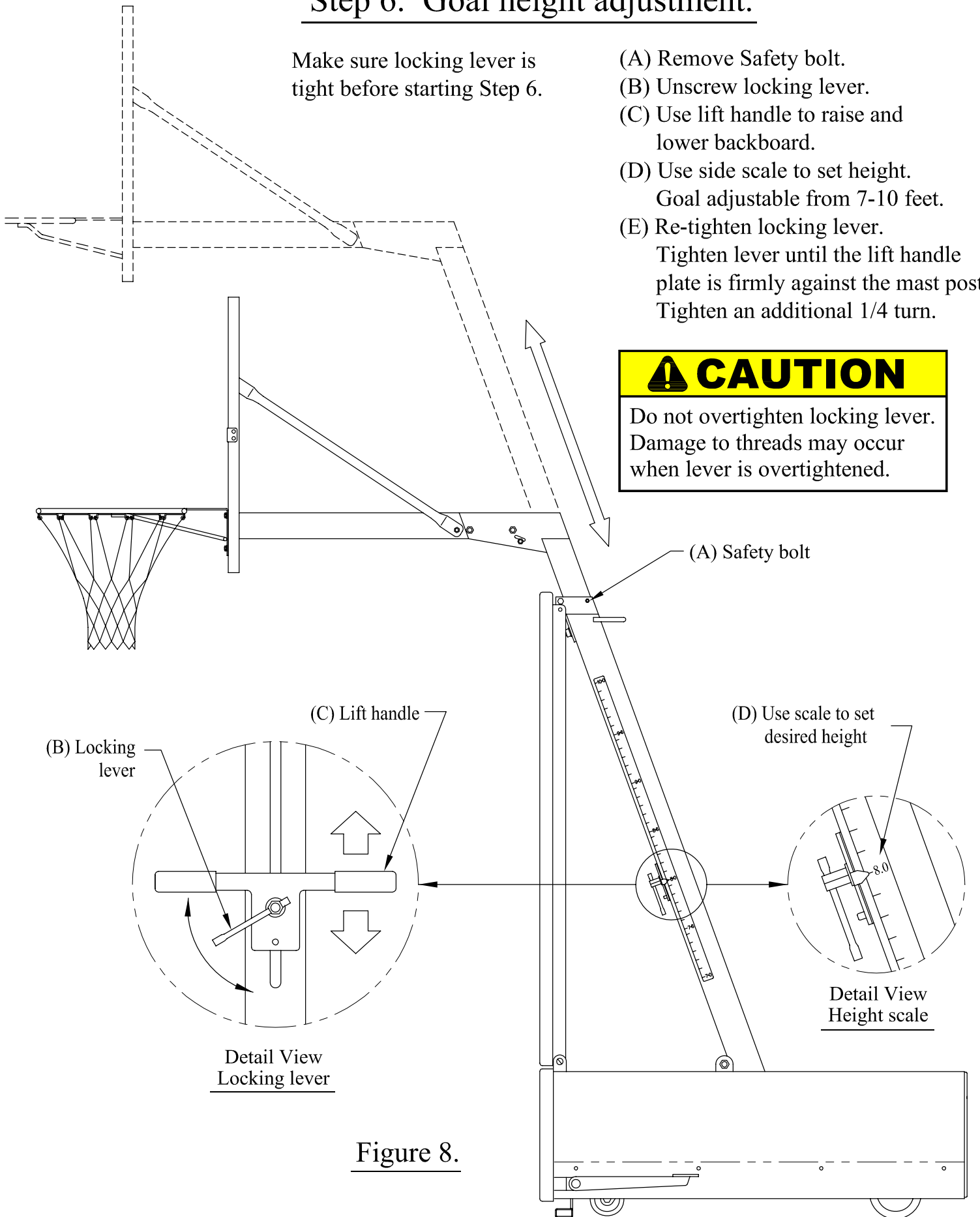

Figure 8.

Step 7: Folding goal and slide post assembly for storage.

*NOTE: Please follow step by step procedure for best results.

(A) Make sure the 3/8" bolt is in proper position for folding sequence. See detail view.

(B) Loosen 1/2" bolts at boom extension bracket.

(C) Remove front bolt and rotate backboard assembly to down position.

(D) Loosen the 1/2" nut at the top of the slide post just behind the pad.

(E) Carefully rotate the slide post assembly to full down position. See fig. 10

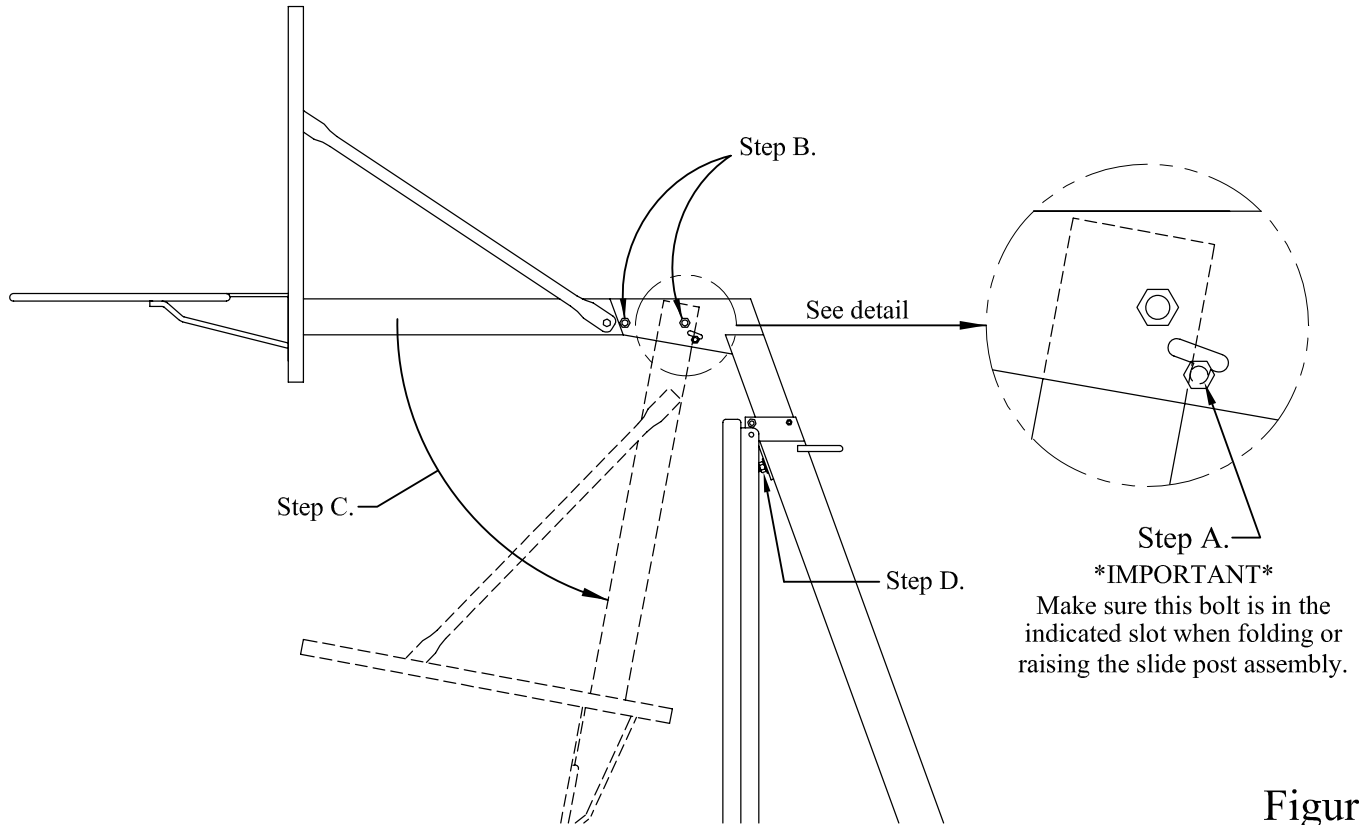

Figure 9.

Step 8: Storage position.

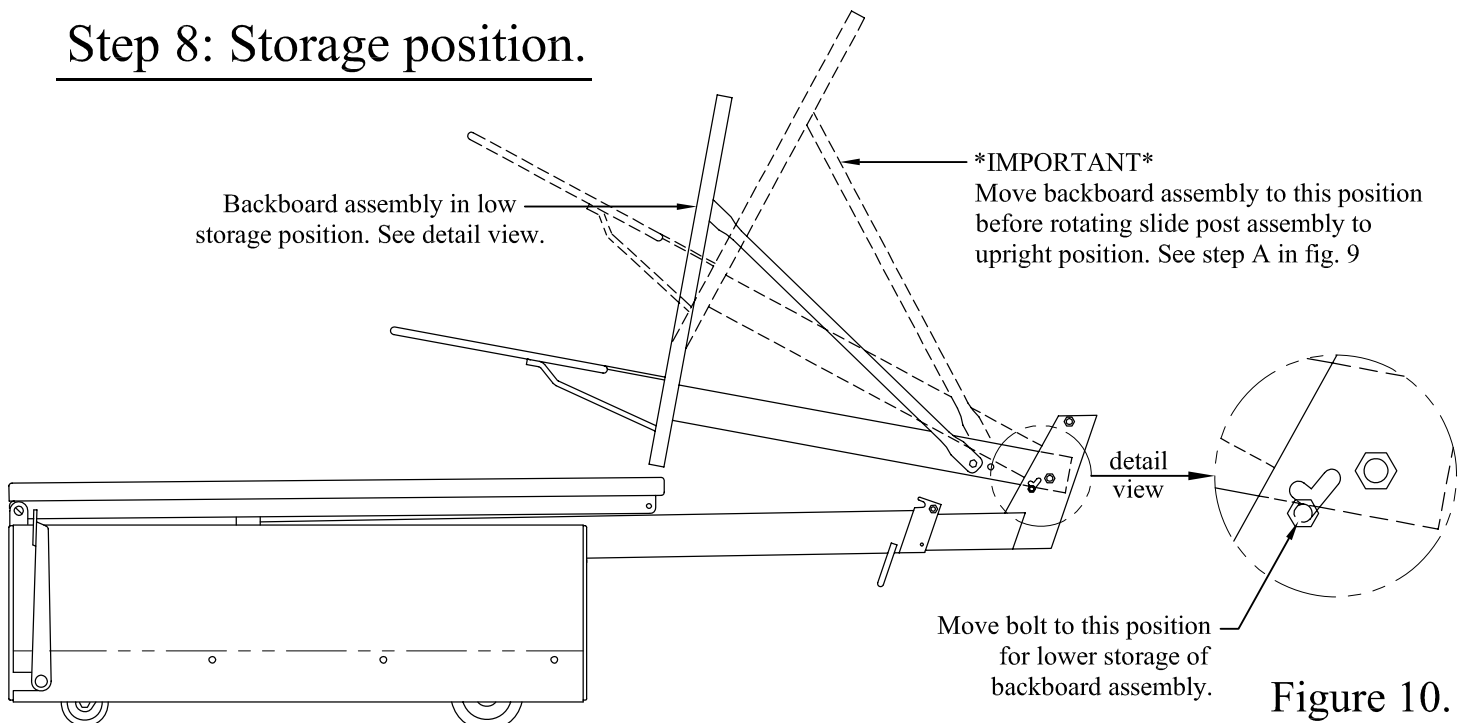
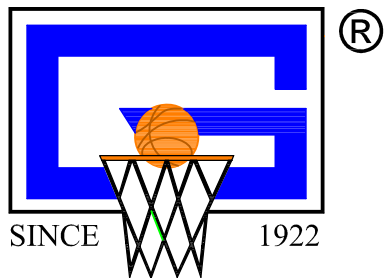

Figure 10.



GARED SPORTS

Tel: 1-800-325-2682 Fax: (314) 421-6014
www.garedsports.com E-mail: info@garedsports.com