

Varsity TOSS BACK[®]

Assembly Manual

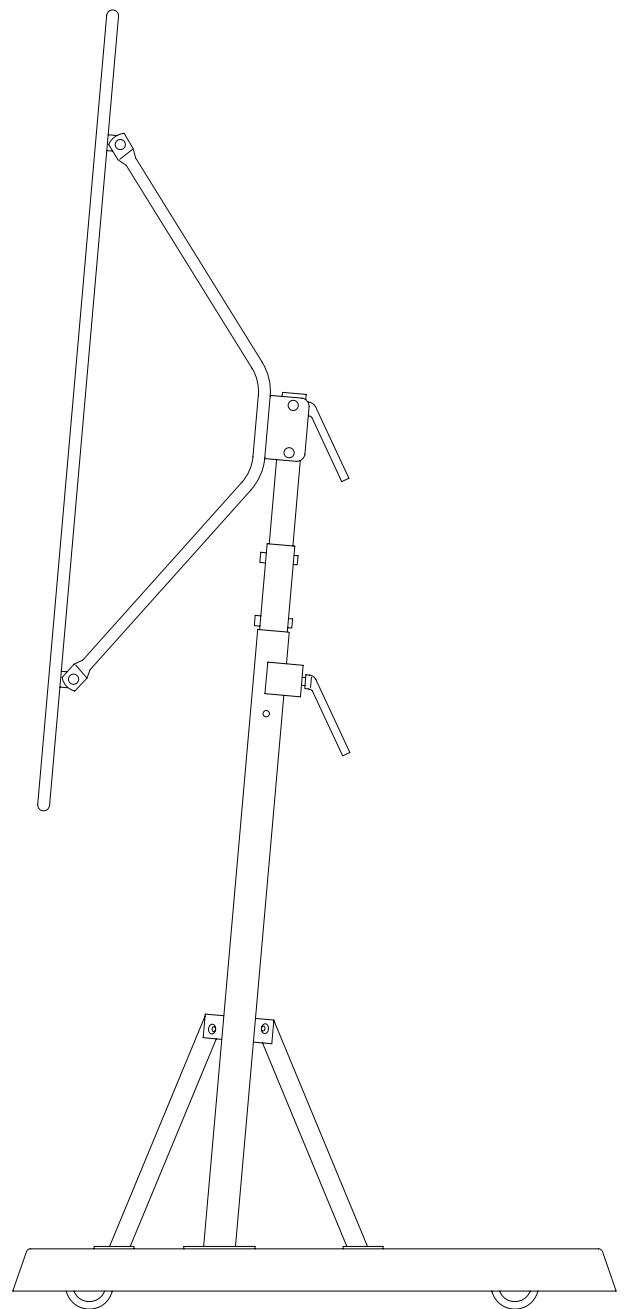

UNPACK AND IDENTIFY ALL PARTS SHOWN.

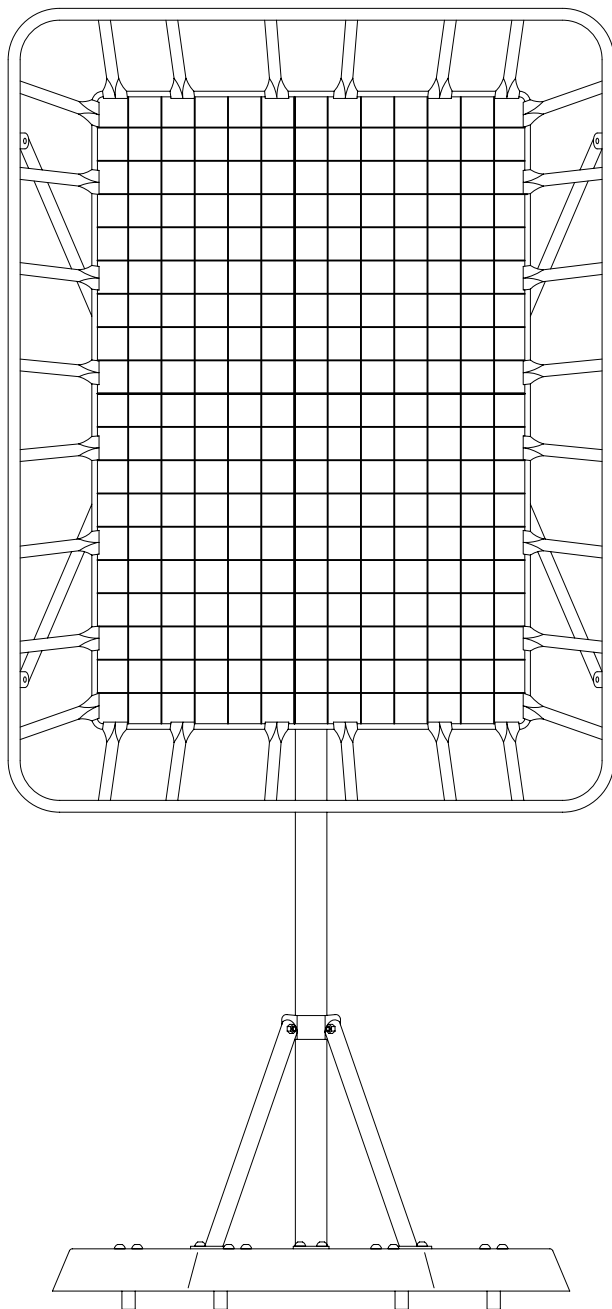
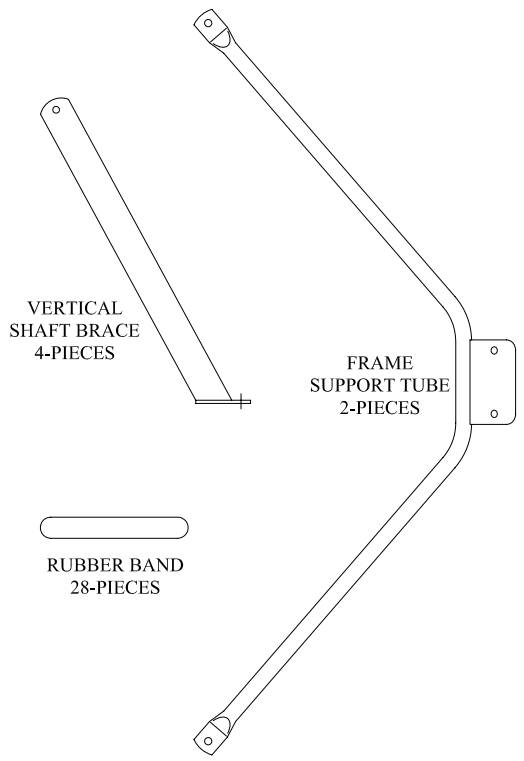
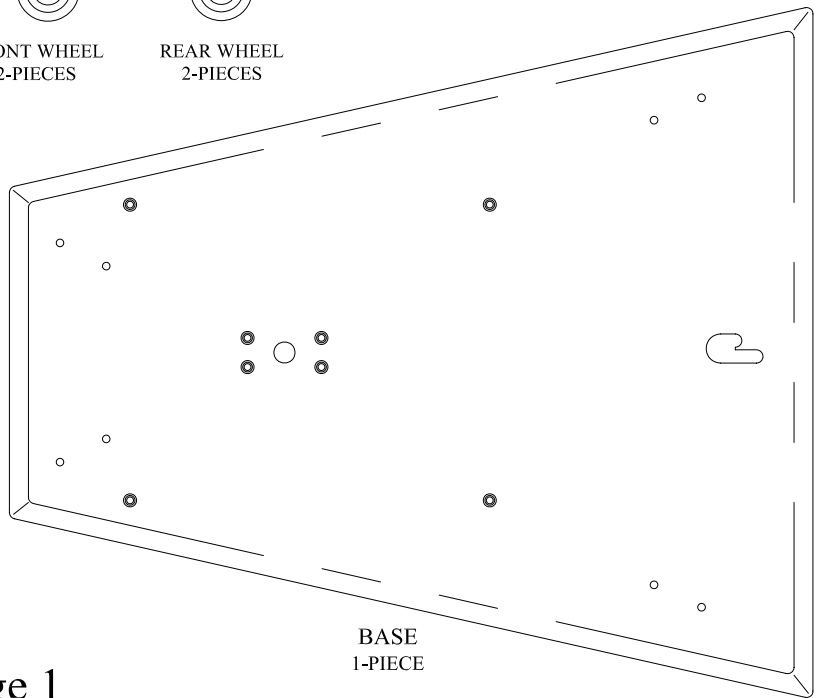
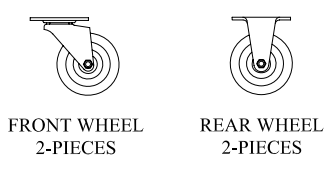
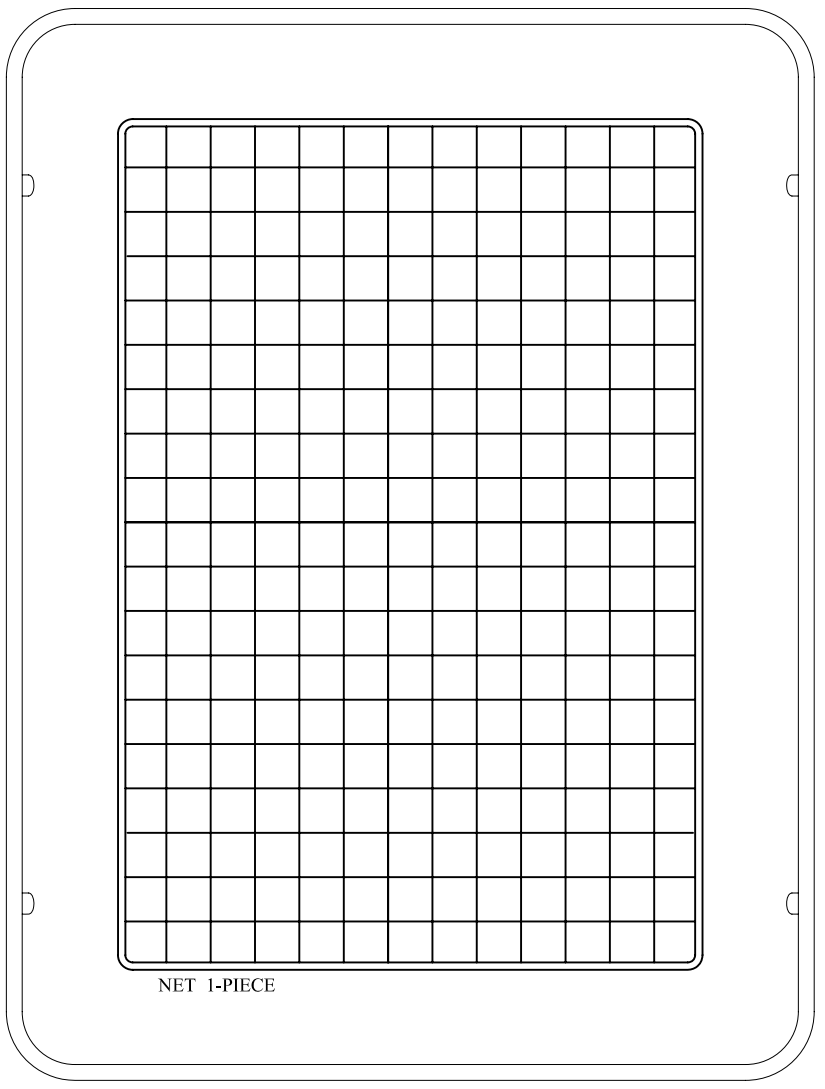
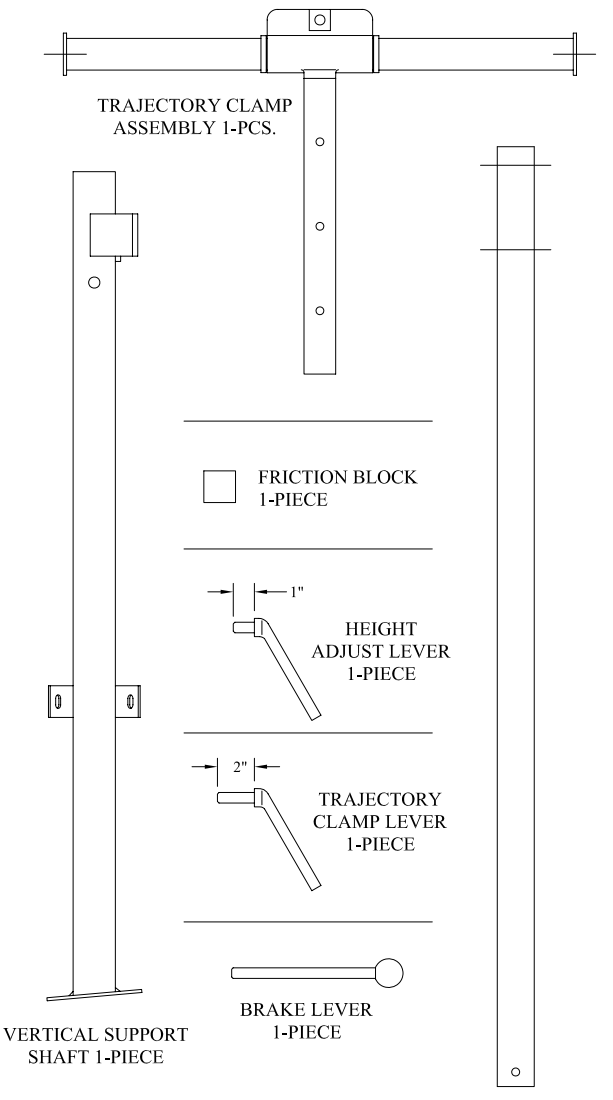

TOOLS REQUIRED FOR ASSEMBLY

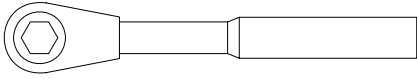

(Optional)

RATCHET WRENCH WITH 12 MM SOCKET







(2 required)

12 MM OPEN END WRENCH

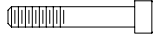

6 MM ALLEN WRENCH

ASSEMBLY HARDWARE

	A	B	C	D	E	F	G
ITEM	 5/16" X 3/4" LONG SOCKET HEAD MACHINE SCREW		 5/16" NUT WHIZLOCK		 5/16" X 2" LONG CAP HEAD SCREW	 5/16" FLAT WASHER	 5/16" LOCK WASHER
QTY.	(20)		(14)		(2)	(2)	(8)

STEP NO. 1 ASSEMBLE WHEELS

(NOTE: IF WHEELS ARE PRE-INSTALLED GO TO STEP NO. 2)

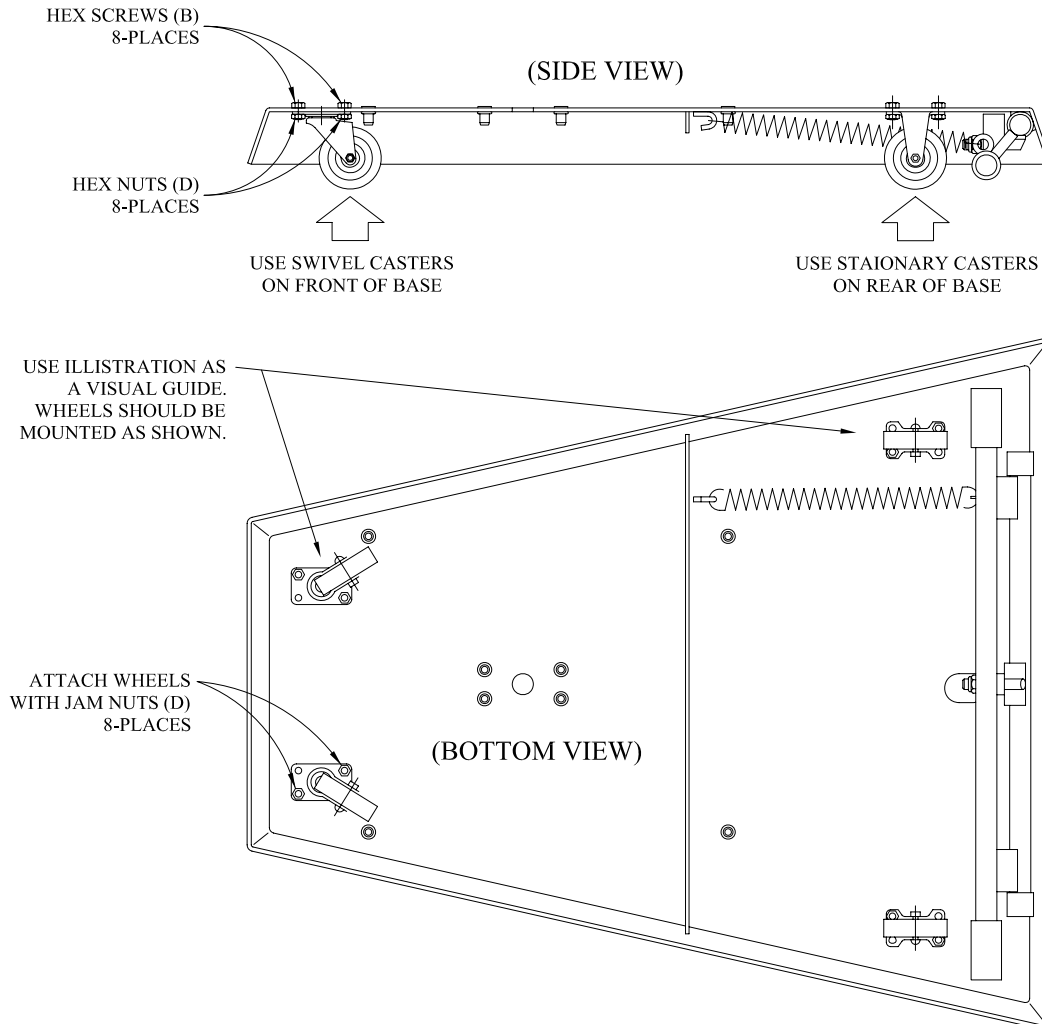

STEP NO. 2 ASSEMBLE VERTICAL SUPPORT COLUMN.

A. ASSEMBLE VERTICAL COLUMN FIRST.

B. ADD (4) BRACES SECOND.

NOTE: READ ALL NOTES BEFORE BEGINNING ASSEMBLY.
REFER TO ASSEMBLY HARDWARE ON PAGE 2.

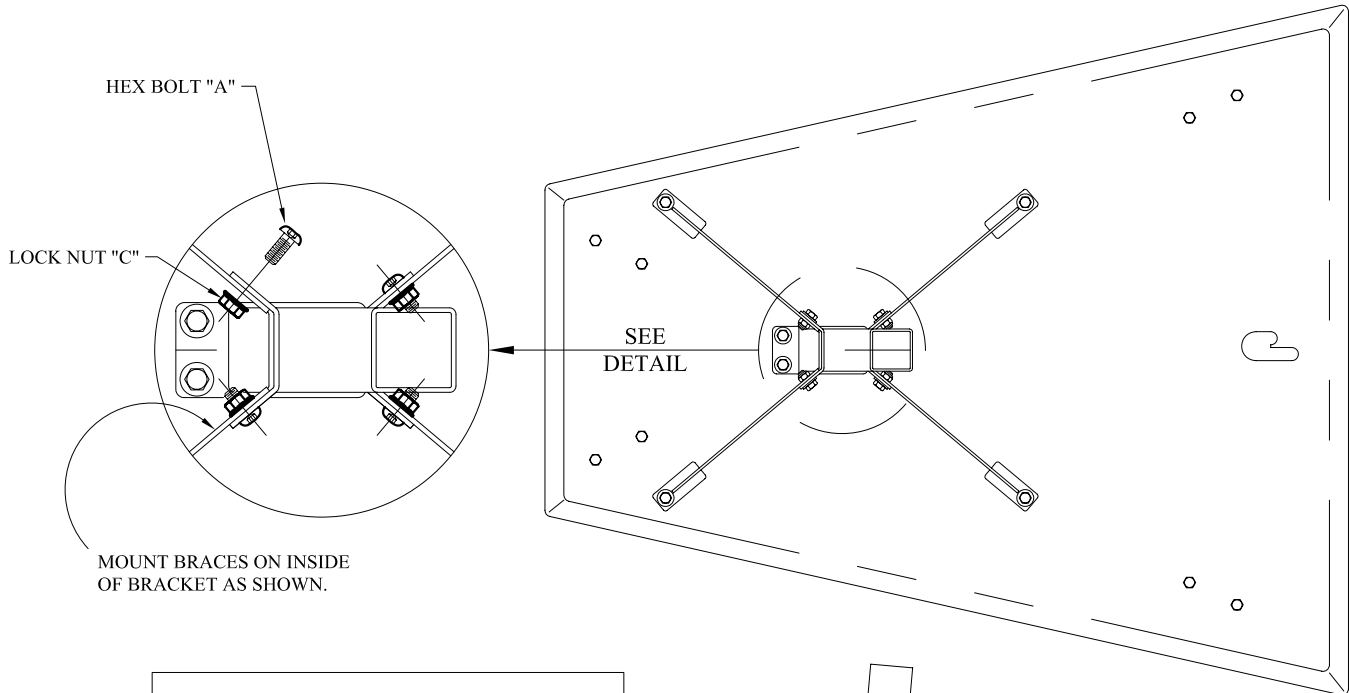

NOTE:
LEAVE ALL FASTERS LOOSE
UNTIL ALL PARTS IN PLACE.

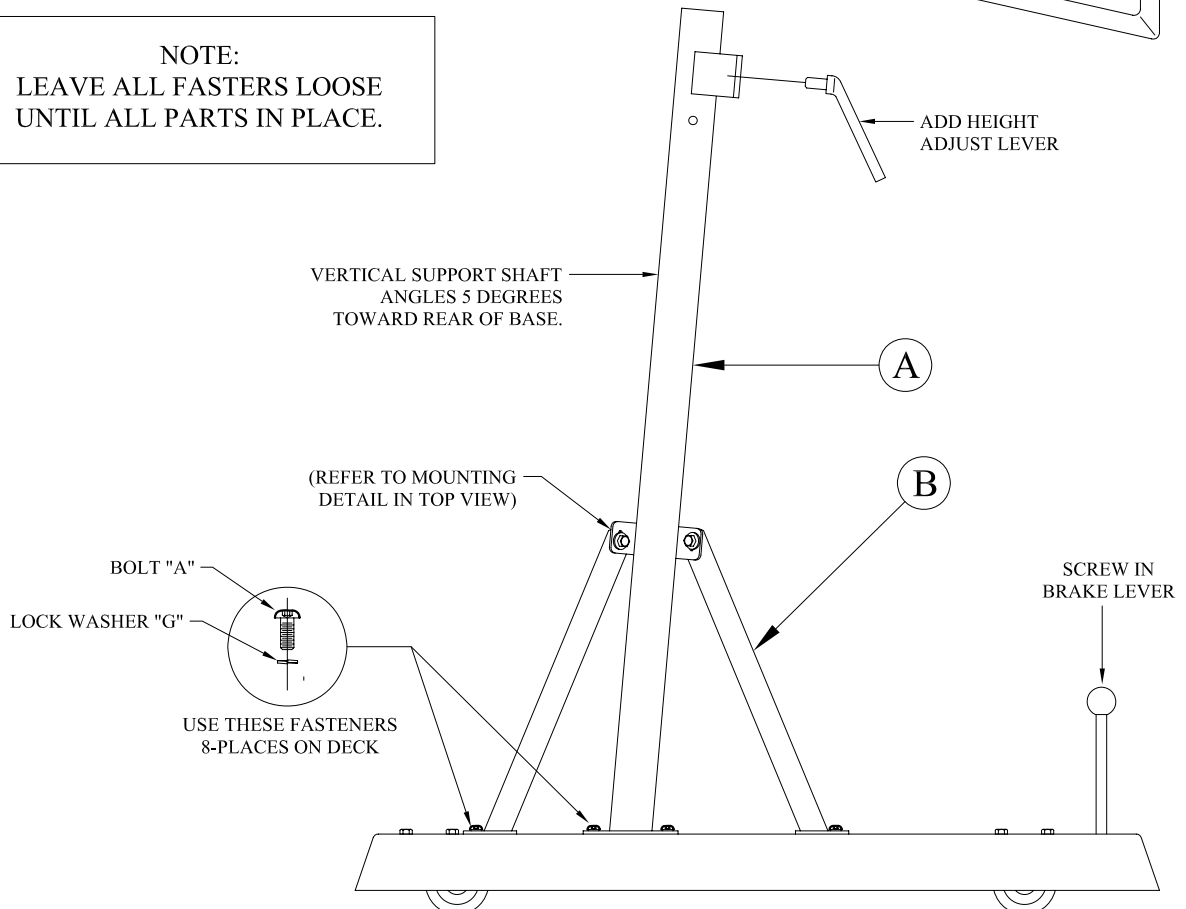

STEP NO. 3 ASSEMBLE NET FRAME.

NOTE: READ ALL NOTES BEFORE BEGINNING ASSEMBLY.
REFER TO ASSEMBLY HARDWARE ON PAGE 2.

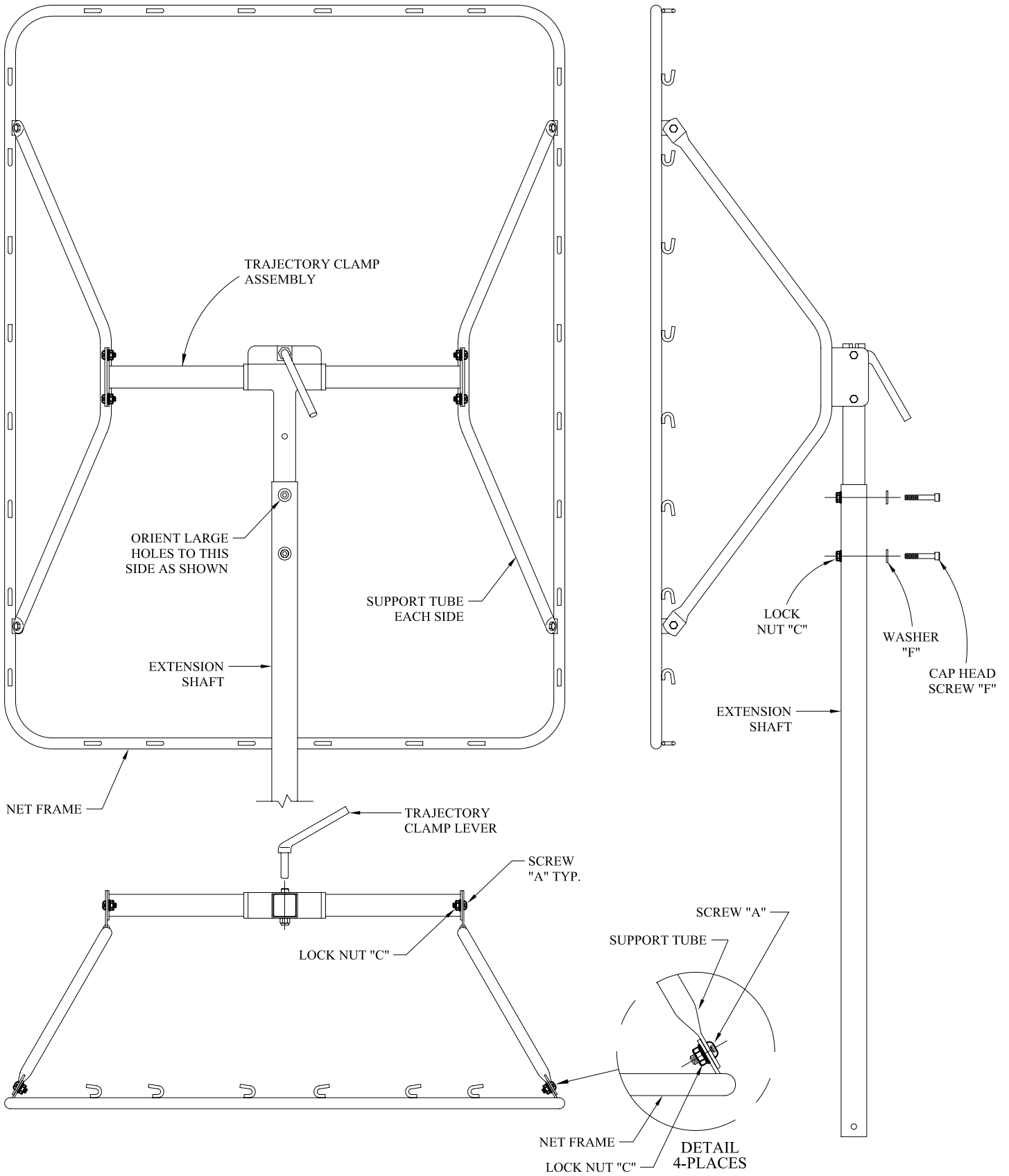

STEP NO. 4 ASSEMBLE THE NET.

NOTE: INSTALL NET FRAME ON BASE AND LOCK IN PLACE.
APPLY BASE BRAKE BEFORE BEGINNING TO INSTALL NET.

STRETCH THE NET WITH 28 RUBBER BANDS AROUND THE PERIMETER OF THE FRAME AS INDICATED. USE THE ILLUSTRATION AS A GUIDE FOR THE PLACEMENT OF EACH RUBBER BAND. SUGGEST ALTERNATING BANDS SIDE TO SIDE DURING INSTALLATION PROCESS.

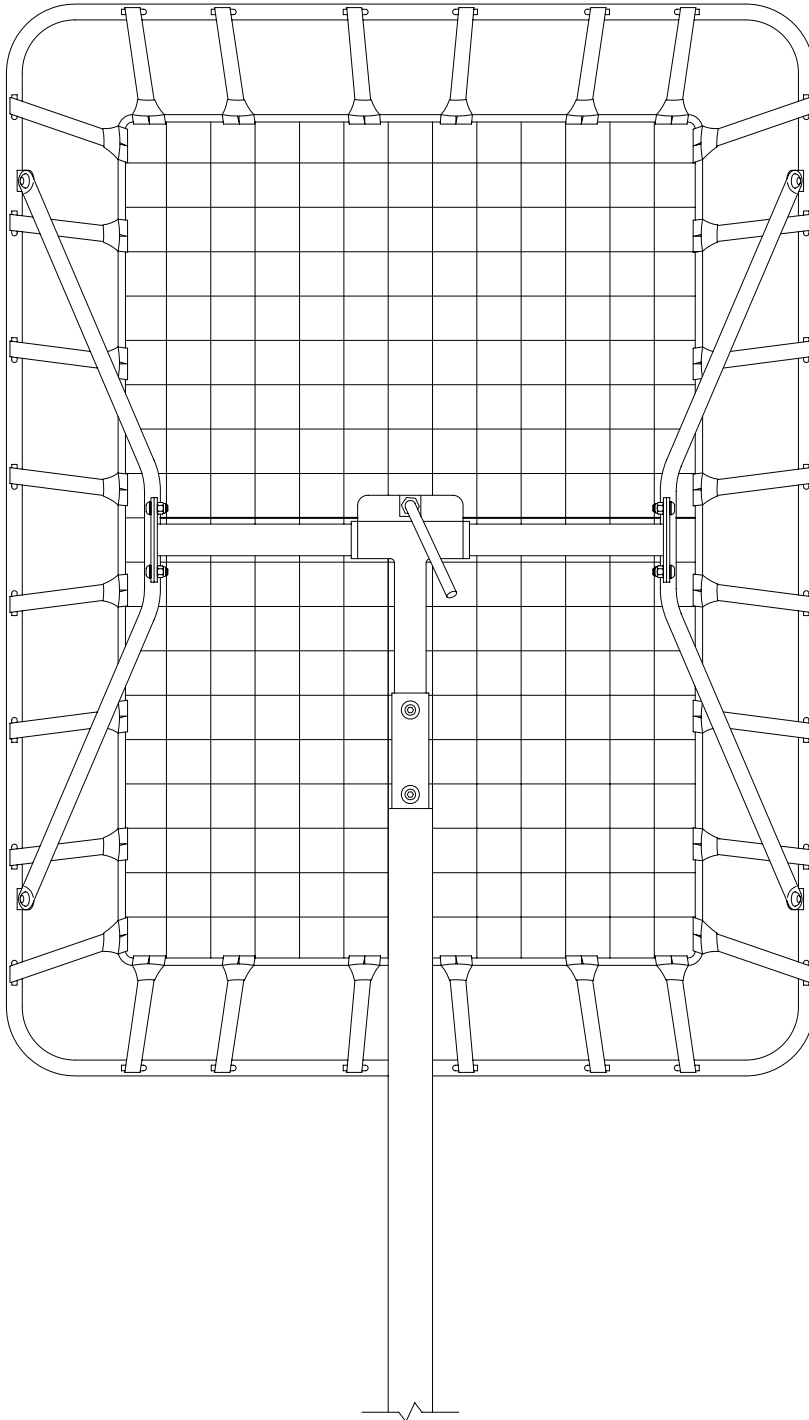

USE THIS SEQUENCE AS A GUIDE TO HELP STRETCH THE RUBBER BANDS.

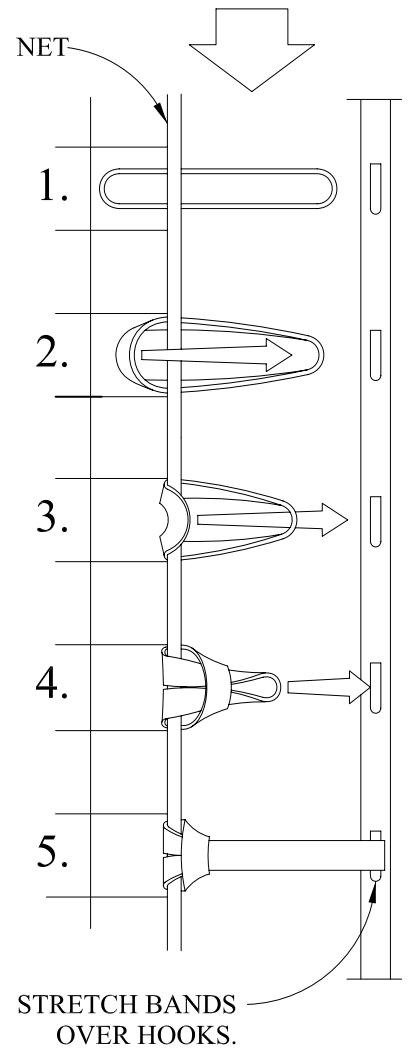

SIDE VIEW OF ASSEMBLED UNIT.

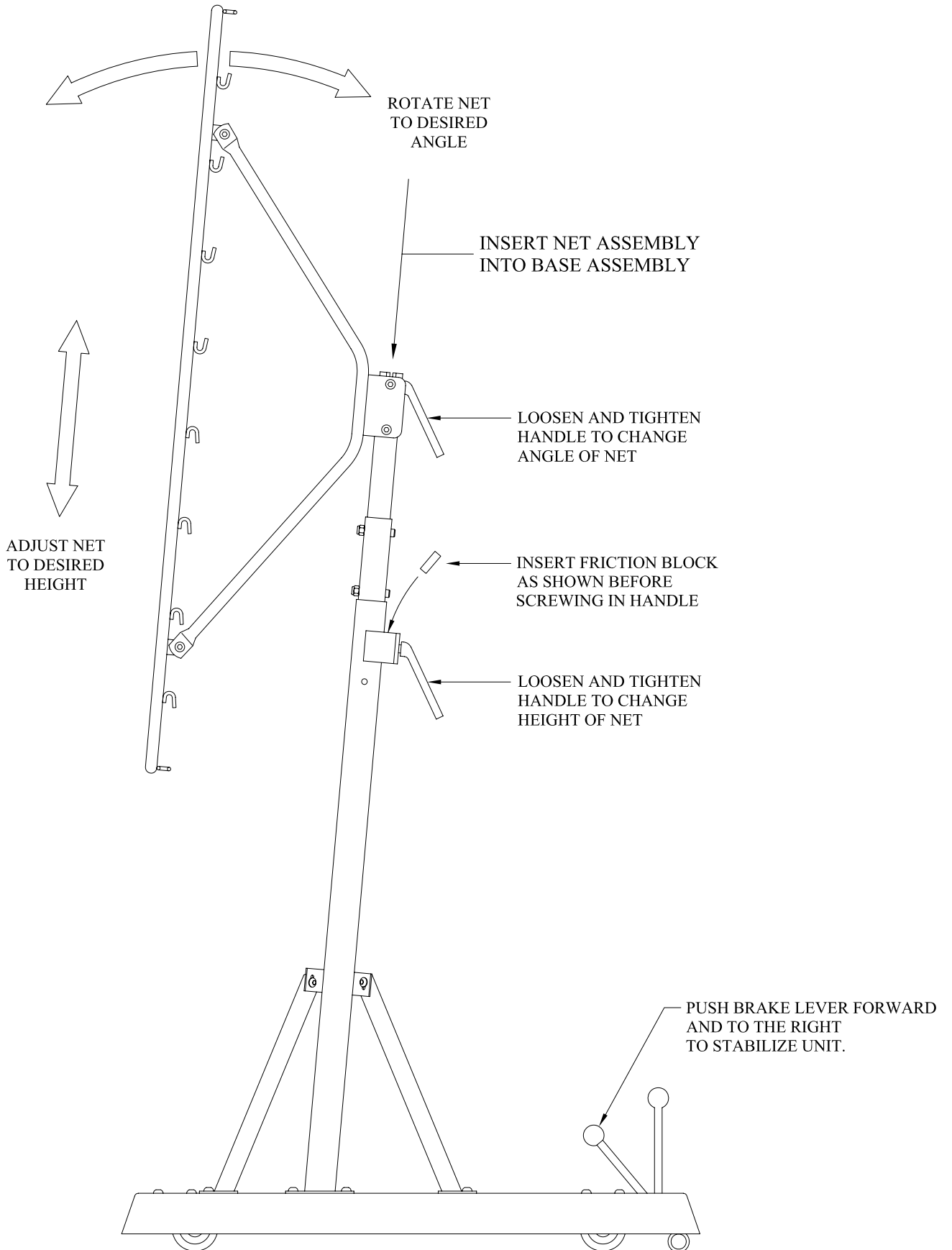

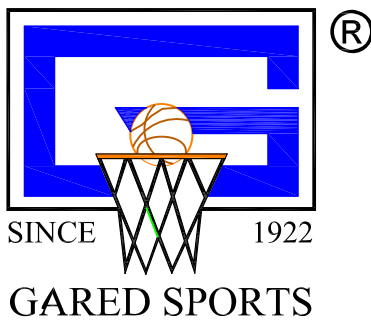

Tel: 1-800-325-2682 Fax: (314) 421-6014
www.garedsports.com E-mail: info@garedsports.com